



Ph: 1300 214 015  
 info@unisonjoints.com.au  
 2/282 New Cleveland Rd  
 Tingalpa, Queensland 4173

**UNISON JOINTS**  
 Pty. Ltd.

Model:

Project:

**Mo50DL**  
 (UAST50D LP)

Material:  
 Anodised Aluminium  
 Thermoplastic Seal  
**Do Not Scale**

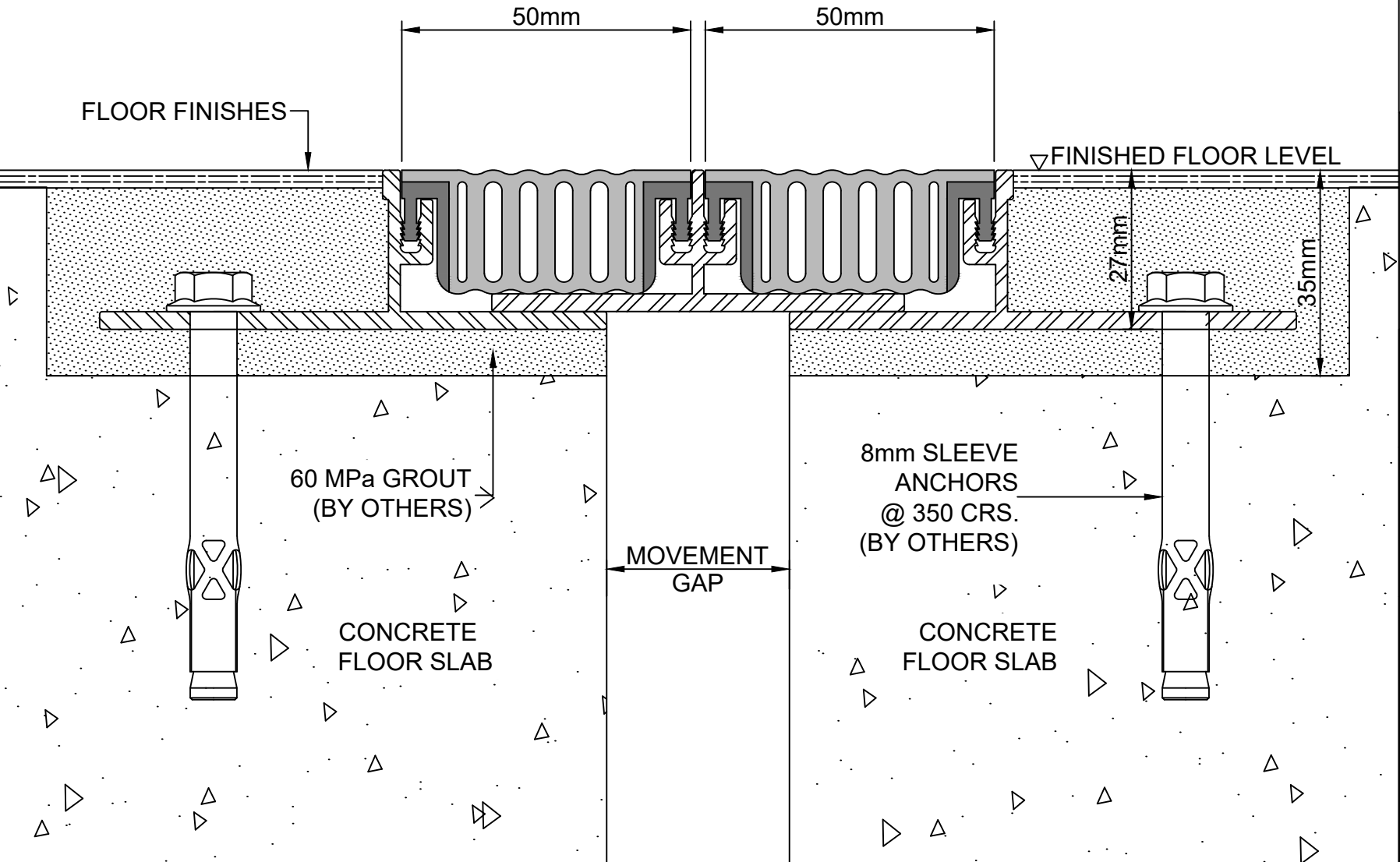

Disclaimer: All design rights reserved. Design and specifications are subject to change without notice. The manufacturer does not accept liability where the material on these pages is misconceived, exploited or lacks conformity. The intention of this information is to provide a reasonable description of products, procedures and capabilities. Rev.3