



Ph: 1300 214 015  
 info@unisonjoints.com.au  
 21282 New Cleveland Rd  
 Tingalpa, Queensland 4173



**UNISON**  
**JOINTS**  
 Pty. Ltd.

Model:

**Fx70CT**  
 (UAC70T)

Material:

Anodised Aluminium  
 Do Not Scale

Project:

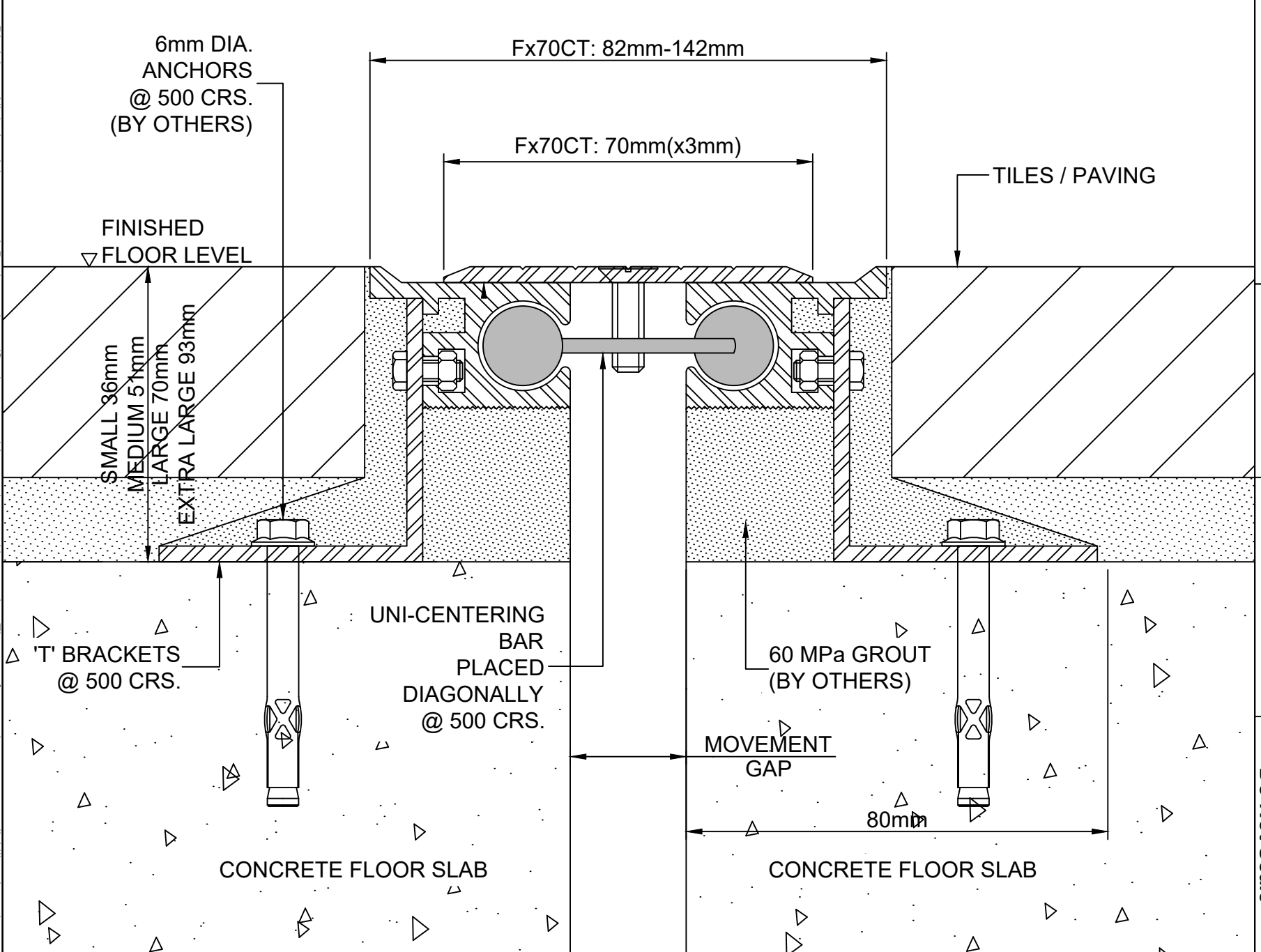

6mm DIA.  
 ANCHORS  
 @ 500 CRS.  
 (BY OTHERS)

Fx70CT: 82mm-142mm

Fx70CT: 70mm(x3mm)

TILES / PAVING

FINISHED  
 FLOOR LEVEL

SMALL 86mm  
 MEDIUM 51mm  
 LARGE 70mm  
 EXTRA LARGE 93mm

'T' BRACKETS  
 @ 500 CRS.

UNI-CENTERING  
 BAR  
 PLACED  
 DIAGONALLY  
 @ 500 CRS.

60 MPa GROUT  
 (BY OTHERS)

MOVEMENT  
 GAP

80mm

CONCRETE FLOOR SLAB

CONCRETE FLOOR SLAB

Disclaimer: All design rights reserved. Design and specifications are subject to change without notice. The manufacturer does not accept liability where the material on these pages is misconceived, exploited or lacks conformity. The intention of this information is to provide a reasonable description of products, procedures and capabilities. Rev.3